

# 衬氟自控球阀 Lined Control Ball Valve

## 主要参数及性能 Technical Specification

设计标准 Design & Manufacture Standard	HG/T3704, API 6D
结构长度标准 Face-to-face Dimension	HG/T3704, GB/T12221, ASME B16.10
法兰标准 Flange Connection	HG/T20592, GB/T9119, ASME/ANSI 16.5, JIS B2220
检测与试验标准 Inspection & Test Standard	GB/T4213, GB/T13927, GB/T26144, API598
密封面标准 Sealing surface Standard	HG/T 20592 RF, ASME B16.5 RF
实际压力 Actual Pressure	最大1.0 MPa(1.6 MPa特制) Maximum 1.0MPa (1.6MPa customised)
公称压力 Nominal Pressure	0.6MPa, 1.0MPa, 1.6MPa; 150LB; JIS 10K
工作温度 Working Temperature	-29°C ~200°C
全行程时间 Full Travel Time	全开或全关所用时间为4~35秒 4~35 seconds when fully open or fully close
流量特性 Flow Characteristic	近似等百分比 Approximate equal percentage
执行机构 Actuator	配用ACT系列或者AW系列活塞式执行机构 Equipped with ACT series or AW series piston actuator
供气压力 Pressure Supply	气源压力Air pressure: 0.5 MPa
气源接头 Air Supply Connection	Rc1/4
误差 Basic Error	带定位器,基本误差±2%; 回差: < 1.5%; 死区: 0.8%; 始终点误差为±1.5%; With positioned:±2%, backlash <1.5%; dead zone: 0.8%; End point deviation: ±1.5%
泄漏量 Leakage Rate	不超过阀门额定Cv值的10 <sup>-5</sup> No more than 10 <sup>-5</sup> of rated CV
选购附件 Optional Accessories	定位器、空气过滤压器、电磁阀、限位开关等等(按订货要求配套提供) positioner, air set, solenoid valve, limit switch etc. (according to the order)

### Kv值-流量系数 Kv Flow Coefficient

DN		20	25	32	40	50	65	80
Kv	O球 O-port	38	50	112	170	255	384	512
	V球 V-port	11	25	36	63	100	184	280

DN		100	125	150	200	250	300
Kv	O球 O-port	940	1420	2220	3580	5120	7350
	V球 V-port	400	580	940	1540	2500	3900

### 流量特性曲线 Flow Characteristic Curve

V型阀的流量特性为近似等百分比特性, 如下图所示

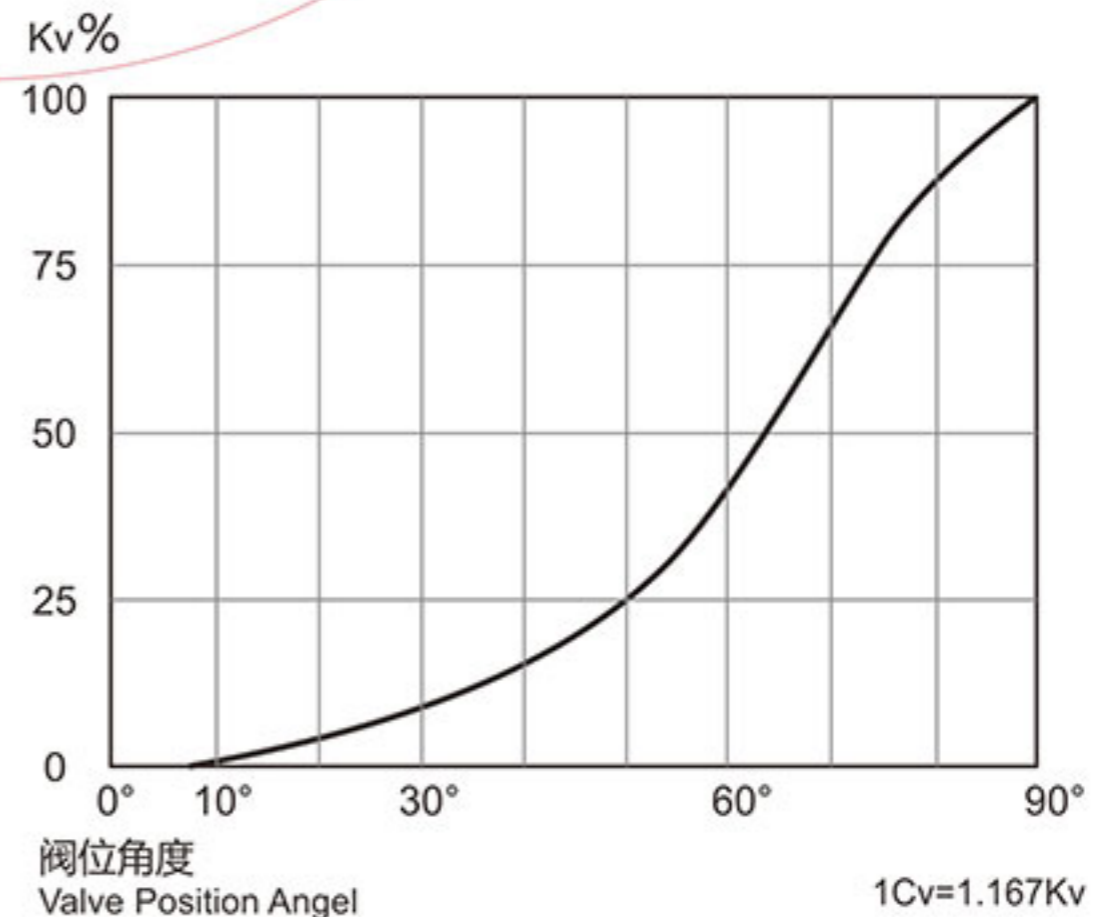

注: 更多尺寸, 请联系有氟密工程师。  
Note: For more size, please consult our engineer.

# 衬氟自控球阀 Lined Control Ball Valve

## 结构与工作原理 Structure and Working Principle



图1 photo 1

● 衬氟自控球阀是由阀体、球体、接体、密封圈、阀盖、填料盖、支架、连接轴执行机构等组成(如图1所示)。一体式球杆使球体旋转球体旋转角度由执行机构驱动,把电、气输入信号转换成阀杆的转动,带动球体在阀体内转动,即球体转动到与输入信号相对应的位置,也可以实现全开—全闭的动作。

● Teflon lined ball valve consists of body, ball, jointing, sealing ring, bonnet, packing gland, bracket, axis actuator and etc. The integrated ball stem makes the ball rotation and the rotating angle is drove by the actuator. Then convert the electric and pneumatic input message into the rotation of stem, rotating the ball inside the body, namely the ball rotates to correspondent position of input message to realized full open and close action.

## 自控衬氟O型切断球阀 Self-control lined O-port on-off ball valve (ZSDOF)

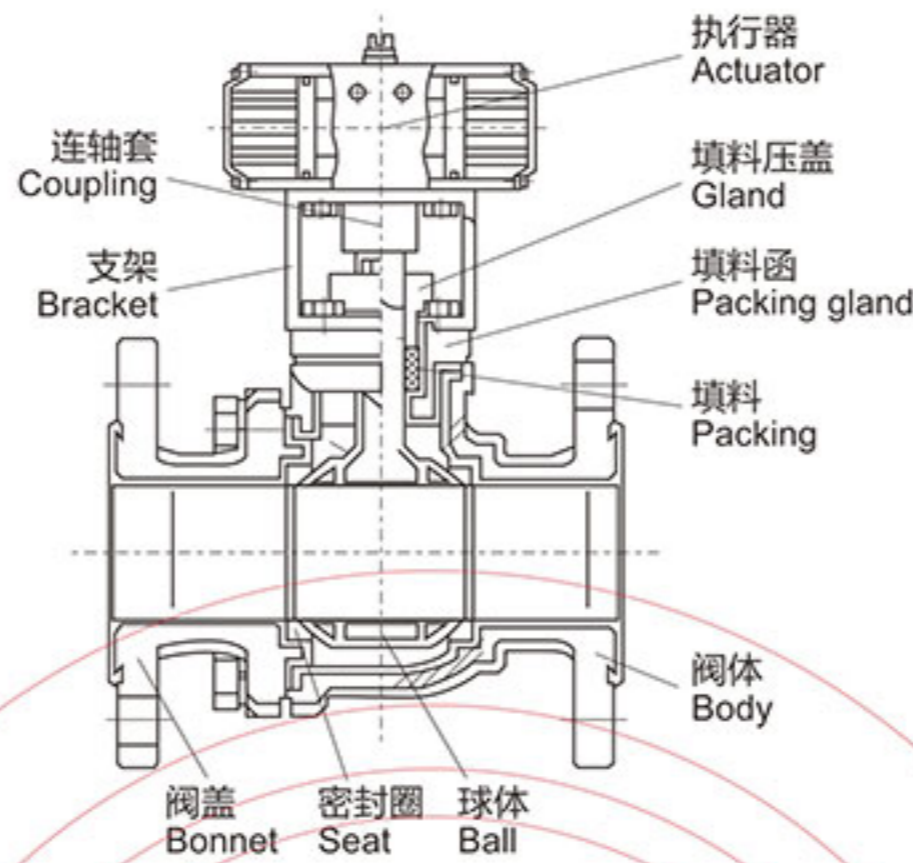
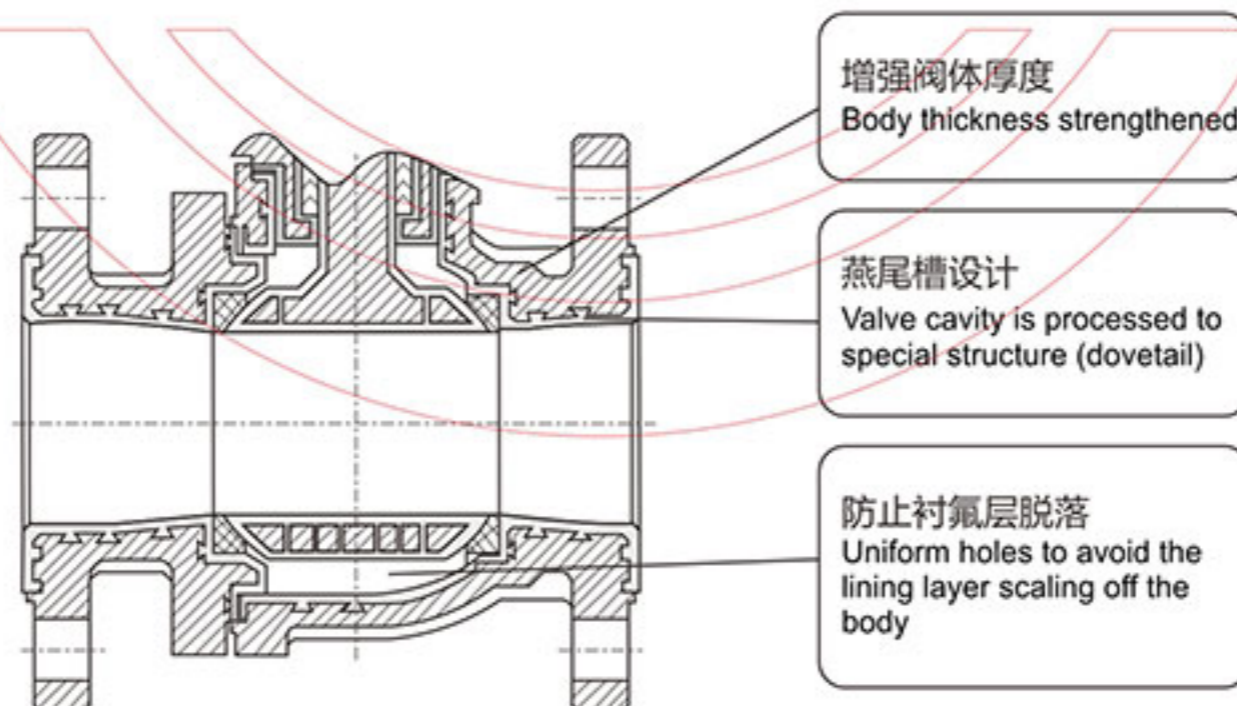

● ZSOF衬氟O型切断球阀是一种360度直角回转的高级切断阀,它与流体接触的阀体内壁和阀内组件均采用注塑或传递模塑衬氟塑料工艺,包覆一层聚全氟乙烯(FEP)、聚四氟乙烯(PTFE)、可溶性聚四氟乙烯(PFA)等防腐蚀材料,完全能达到切断腐蚀性介质与阀体外壳的接触,具有密封性能好,动作灵敏、流体通道呈直线型、流通能力大,与二位五通电磁阀及控制箱配套使用,可实现开关控制。广泛适用于酸、碱等强腐蚀性介质和有毒、易挥发、易渗透、等气体、液体类介质的控制。

● Self-control lined O-port ball valve is a 360°quarter-turn senior on-off valve. All wetted part is lined by PFA/FEP by injection or transfer molding process. It has good seal performance, action quick, linear fluid channel, and big fluid capacity. Equipped with 5/2 way solenoid valve and control box, it can realize on-off control. It can be used in strong corrosive medium such acid, alkali and toxic, volatile, easy penetration medium.

V型调节球阀 (ZSVF)

● ZSVF衬氟V型调节球阀是一种360度直角回转的高级控制阀,它与阀门定位器配套使用,可实现比例调节;与二位五通电磁阀及控制箱配套使用,可实现开关控制。V型球阀阀芯设计成带有特殊形式的V型口,(V型口可根据不同的角度来实现调节精度)具有精确的流量特性和控制能力,适用于各种控制场合。具有额定流量系数大,可调比大,密封性能优越,结构紧凑,体积小,可竖卧安装等优点。由于阀芯和阀座之间是无间隙回转,所以具有很大的剪切及自洁能力,尤其适用于含有纤维性或软质颗粒的悬浮液的控制。在与流体接触的阀体内壁和阀内组件均采用注塑或传递模塑衬氟塑料工艺,包覆一层聚全氟乙烯(FEP)、聚四氟乙烯(PTFE)、可溶性聚四氟乙烯(PFA)等防腐材料,完全能达到切断腐蚀性介质与阀体外壳的接触,具有密封性能好,动作灵敏、流体通道呈V型、压降损失小、阀容量大、流量特性精确,广泛适用于酸、碱等强腐蚀性介质和有毒、易挥发、易渗透等气体、液体类介质的控制。

Lined V-port ball control valve (ZSVF)

● ZSVF lined V-port ball valve is a 360°quarter-turn senior control valve. With the positioner, proportional control can be realized, and with the 5/2 way solenoid valve and control box, it can realize the on-off control. The V-port is designed according to required flow rate to achieve accurate flow characteristic and control ability. It characterized with large rated flow coefficient, large adjustable ratio, superior sealing performance, compact structure, and can be installed vertically. As there is no gap between valve core and valve seat, it has the shear function and self-cleaning, which is especially suitable for the fibrous medium or containing soft particle. All wetted part is lined by PFA/FEP by injection or transfer molding process. It can be used in strong corrosive medium such acid, alkali and toxic, volatile, easy penetration medium.

流量系数表 Flow Coefficient Table

DN		Cv值			
		O-Port	V30°	V45°	V60°
25	1"	18.2	5	8	12
32	1 1/4"	28.5	8	12	18
40	1 1/2"	47	13	20	30
50	2"	73	21	31	46
65	2 1/2"	114	32	48	72
80	3"	181	51	76	115
100	4"	292	82	123	185
125	5"	456	128	192	289
150	6"	712	201	300	452
200	8"	1025	289	432	650

Kv值与Cv值之间的关系:  $1Cv=1.167Kv$

V型球阀V型切口示意图 V-port Options

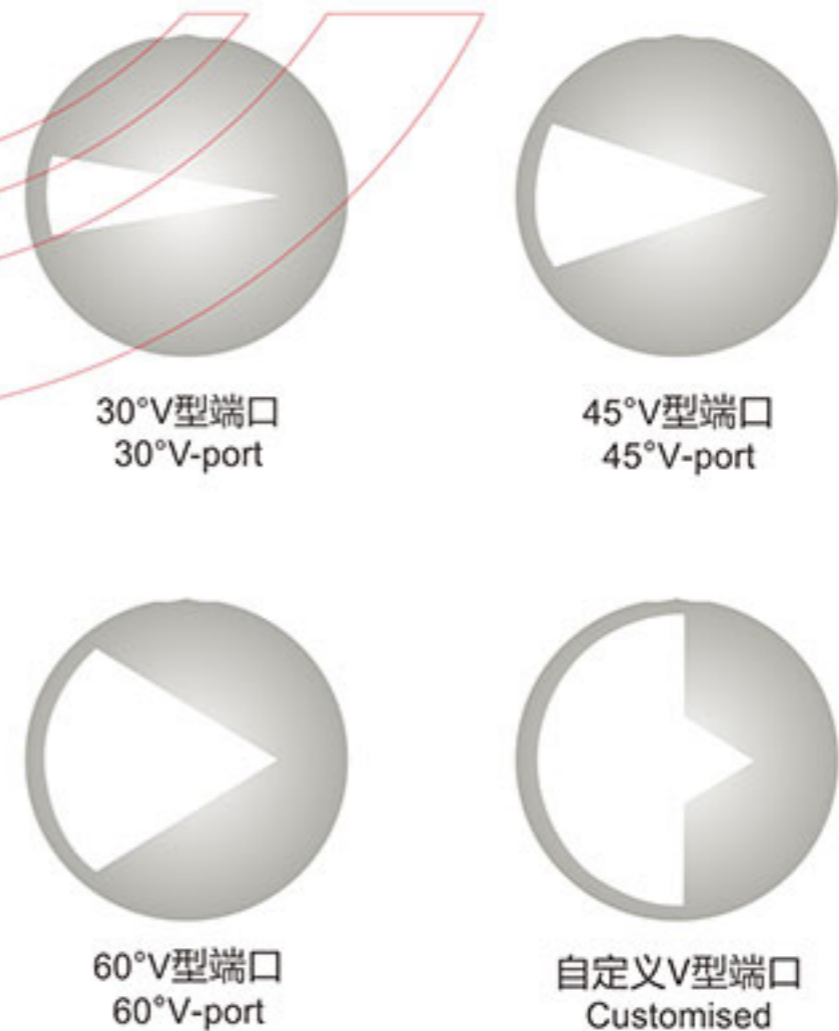

## 技术性能规范 Technical Specification

技术指标 Technical Index	不带定位器 Without positioner	带定位器 With positioner
基本误差 Basic error(%)	±5	±1.5
回差 Backlash (%)	-	1.5
死区 Dead zone(%)	±4	0.6
额定行程偏差 Deviation of rated travel(%)	+4	+2.5
允许泄漏量 Allowed leakage	VI级 (或无泄漏) VI grade (or no leakage)	$5 \times 10^{-6} \times$ 阀额定容量 $5 \times 10^{-6} \times$ Valve rated volume
可配附件 Optional accessories	电气定位器或电/气转换器、空气过滤减压器、电磁阀、手轮机构等 Electric positioner or electric/pneumatic transverter, air set, solenoid valve, hand wheel etc.	
额定流量系数Kv偏差 Rated flow rate coefficient Kv difference(%)	±10%	

## 主要零件材料 Material Specification

零件名称 Name	材料 Material
阀体、阀盖、填料压盖 Body, Bonnet, packing gland	铸钢件+内衬里为氟塑料(WCB/CF8+FEP/PFA) Cast steel+ lining materials (WCB/CF8+FEP/PFA)
一体式阀杆 Ball & stem	铸钢件+内衬里为氟塑料(WCB/CF8+FEP/PFA) Cast steel+ lining materials (WCB/CF8+FEP/PFA)
阀座、填料 Seat, packing	聚四氟乙烯(PTFE)
气缸Cylinder	挤压铝(氧化) Pressing aluminum (oxidized)
活塞Piston	压铸铝(镀镍) Cast aluminum (nickel plated)

## 安装与维修

- 产品使用的环境温度为-29°C~70°C。因为活塞的橡胶零件，在过低温度下易硬化变脆，高温时会加速老化。
- 产品最好正立安装。如安装位置不允许，也可与垂直线成一角度。倾斜安装时，应考虑加设支架。
- 手轮机构使用后，必须将手动/自动操作杆置于自动位置，否则会影响自动控制。
- 衬氟球阀安装在管道上之前，应彻底清洗管道系统的杂质和污物，以免阀门运行部件卡死，或损坏密封圈、球体密封面等重要零件。
- 衬氟球阀安装时，介质流向应与箭头方向一致。

## Installation and Maintenance

- The applicable temperature for lined control butterfly valve is -29°C ~70°C. Since the piston is rubber parts, it is easily hardening and brittle under extreme low temperature, and aging accelerates under high temperature.
- This valve is better for vertical installation; if not allowed, consider adding the support bracket for slanting installation.
- After hand wheel actuator used, the telescopic pipe should be returned to top end, or will affect automatic control.
- It should clean the impurities and dirt on pipeline before the lined ball valve before installed, to avoid the running parts stuck, or damage the important parts of seat and disc sealing face.
- When the lined ball valve installed and there is leakage, it should tighten the bolts between upper and lower bodies until no leakage.

衬氟自控球阀 Lined Control Ball Valve

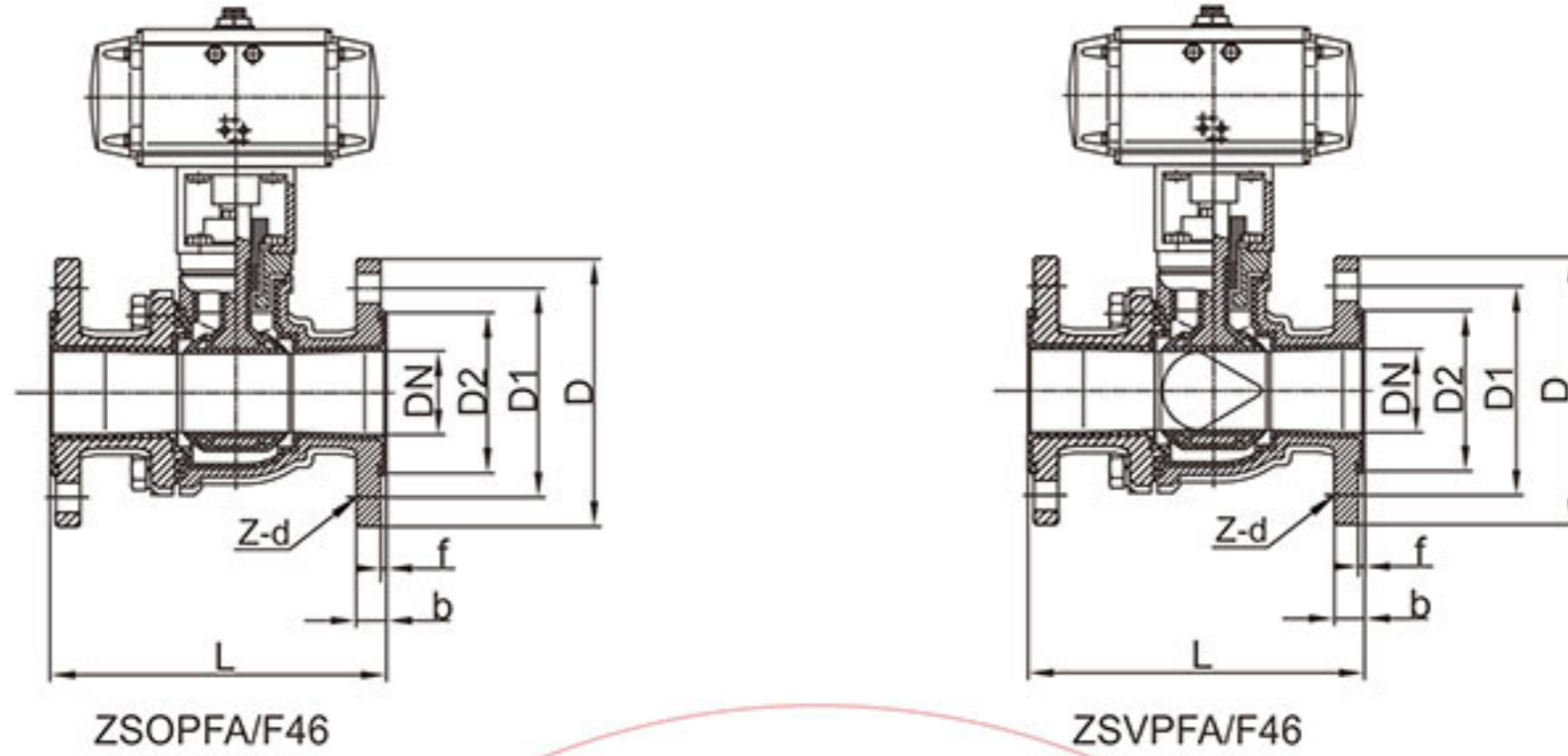

Control Valve 自控阀

HG/T 20592

单位Unit:mm

DN	L	PN10(1.0MPa)						PN16(1.6MPa)						气动执行机构		
		D	D1	D2	b	f	Z-d	D	D1	D2	b	f	Z-d	双作用 Double acting	单作用 Single acting	扭矩 Torque N·m
15	132	95	65	45	16	2.5	4-14	95	65	45	16	2.5	4-14	ACT63D	ACT75S	15
20	142	105	75	55	18	2.5	4-14	105	75	55	18	2.5	4-14	ACT63D	ACT75S	18
25	150	115	85	65	19	3	4-14	115	85	65	19	3	4-14	ACT63D	ACT90S	20
32	165	140	100	78	19	3	4-18	140	100	78	19	3	4-18	ACT75D	ACT90S	25
40	180	150	110	85	19	3.5	4-18	150	110	85	19	3.5	4-18	ACT75D	ACT100S	35
50	200	165	125	100	19	3.5	4-18	165	125	100	19	3.5	4-18	ACT90D	ACT115S	45
65	220	185	145	120	20	3.5	4-18	185	145	120	20	3.5	4-18	ACT100D	ACT125S	70
80	250	200	160	135	21	3.5	8-18	200	160	135	21	3.5	8-18	ACT115D	ACT145S	90
100	280	220	180	155	23	4	8-18	220	180	155	23	4	8-18	ACT125D	ACT160S	130
125	320	250	210	185	25	4	8-18	250	210	185	25	4	8-18	ACT145D	ACT190S	210
150	360	285	240	210	26	4	8-22	285	240	210	26	4	8-22	ACT190D	ACT210S	450
200	400	340	295	265	28	4	8-22	340	295	265	28	4	12-22	AW17	AW20S	880
250	450	395	350	320	29	4	12-22	405	355	320	29	4	12-26	AW20a	AW20S	1800
300	500	445	400	368	29	5	12-22	460	410	375	29	5	12-26	AW20	AW20S	2600

ASME B16.5/JIS B2220

DN	NPS	L	ASME 150LB						气动执行机构		
			D	D1	D2	b	f	Z-d	双作用 Double acting	单作用 Single acting	扭矩 Torque N·m
15	1/2	110	89	60.5	35	12.5	2.5	4-16	ACT63D	ACT75S	15
20	3/4	117	98	70.0	43	14	2.5	4-16	ACT63D	ACT75S	18
25	1	127	108	79.5	51	16	3	4-16	ACT63D	ACT90S	20
32	1 1/4	140	117	89.0	64	17	3	4-16	ACT75D	ACT90S	25
40	1 1/2	165	127	98.5	73	19.5	3.5	4-16	ACT75D	ACT100S	35
50	2	178	152	120.5	92	21	3.5	4-19	ACT90D	ACT115S	45
65	2 1/2	190	178	139.5	105	24	3.5	4-19	ACT100D	ACT125S	70
80	3	203	190	152.5	127	26	3.5	4-19	ACT115D	ACT145S	90
100	4	229	230	190.5	157	27.5	4	8-19	ACT125D	ACT160S	130
125	5	254	255	216.0	186	27.5	4	8-23	ACT145D	ACT190S	210
150	6	267	280	241.5	216	28	4	8-23	ACT190D	ACT210S	450
200	8	292	343	298.5	263	31	4	8-23	AW17	AW20S	880
250	10	330	406	362.5	324	33	4	12-25	AW20a	AW20S	1800
300	12	356	485	432.0	381	33	4	12-25	AW20	AW20S	2600

注: 1. 所选执行机构型号仅供参考 (气源压力大于0.5MPa)

2. 扭矩值为阀门空载时的扭矩, 不含安全系数。

Note: 1 Selected actuator models are for reference only (gas source pressure is greater than 0.5MPa)

2 The above mentioned torque is with no loading and without safety factor.